

**CITY OF LOS ANGELES  
PERSONNEL DEPARTMENT**

**CAREER OPPORTUNITIES FOR ELECTRICAL MECHANICS**

This information is being given to you to describe potential promotional opportunities as an Electrical Mechanic. The career ladders that Electrical Mechanics most commonly enter into are diagrammed below. The duties and requirements for the first promotional levels of these career ladders are also described. We encourage you to examine the options open to you and to prepare yourself for the promotion for which you qualify.

**COMMON CAREER LADDERS FOR ELECTRICAL MECHANICS**

The chart shows the normal career paths of Electrical Mechanics. Normal advancement within the series is to Senior Electrical Mechanic and then to Electrical Mechanic Supervisor. With specific types of experience, promotion to other electrical job class series is also possible.

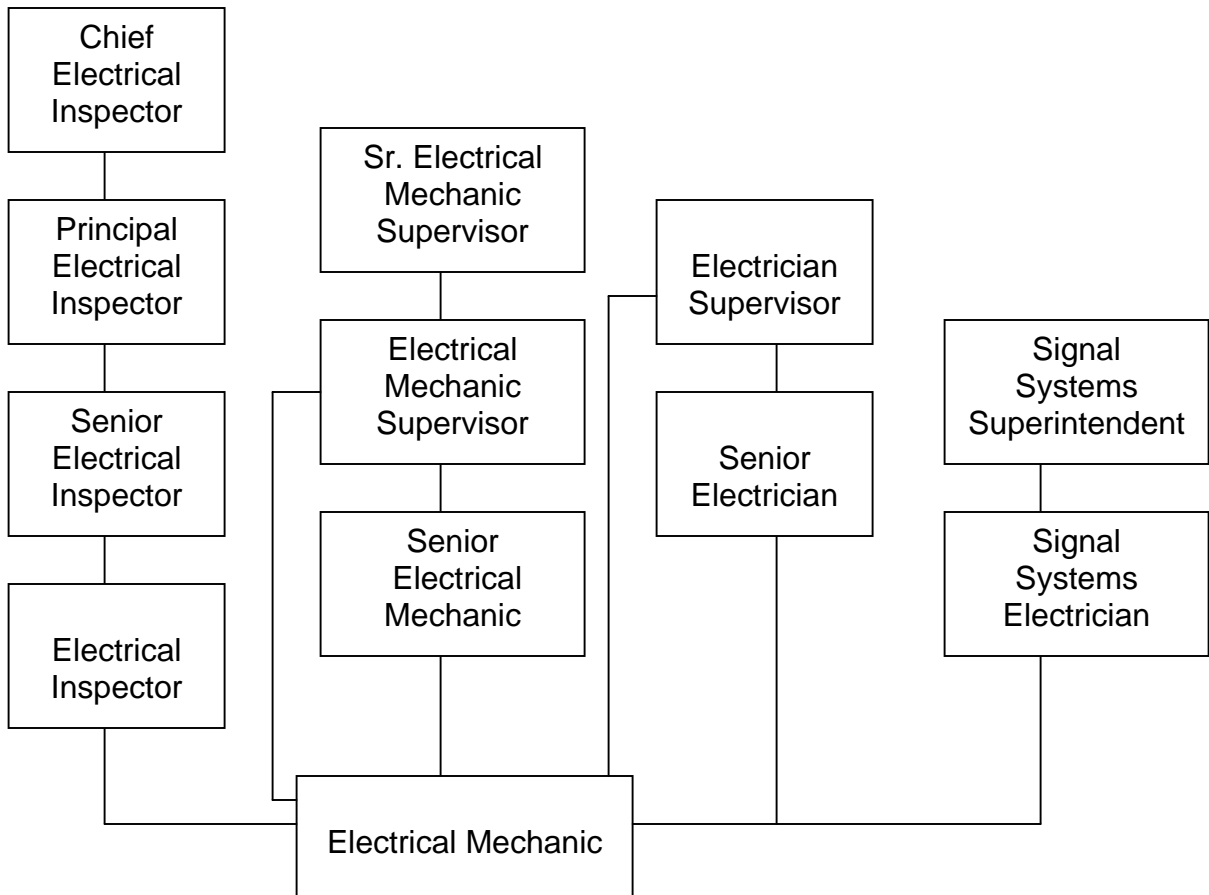

## DUTIES AND REQUIREMENTS OF FIRST PROMOTIONAL LEVEL

### Duties

Senior Electrical Mechanic – A Senior Electrical Mechanic acts as lead for and works with a small group of Electrical Mechanics and helpers performing skilled electrical and mechanical work in installing and maintaining electric equipment in electric stations, generating plants, pumping and chlorinating stations, and similar facilities.

Electrical Inspector – An Electrical Inspector inspects new, existing and modified electrical installations to secure conformance to electrical laws, ordinances and safety provisions; inspects electrical work in public buildings to assure conformance to City plans, specifications, and standards; and assists in training other inspectional employees as required.

Senior Electrician – A Senior Electrician acts as a lead for, and works with, a crew of Electricians and helpers engaged in general electrical installation, maintenance and repair work including motors and lighting, intercom, sound and surveillance systems; keeps records, and makes reports.

Signal Systems Electrician – A Signal Systems Electrician installs, maintains and repairs electric traffic signals, electric and electronic controllers, including microcomputers and other digital microprocessor based traffic signal control devices.

### Requirements

#### Senior Electrical Mechanic

Two years of full-time paid experience as an Electrical Mechanic with the City of Los Angeles.

#### Electrical Inspector

1. Four years of full-time paid experience as an Electrical Inspector with work in residential and commercial or industrial electrical installations; **or**
2. Successful completion of a recognized electrical apprenticeship program and four years of full-time paid electrical experience with work in residential and commercial or industrial electrical installations; **or**
3. Nine years of full-time paid electrical experience with work in residential and commercial or industrial electrical installations; **and**
4. Achievement of a qualifying score on the Electrical Inspector Qualifying Test.

#### Senior Electrician

Two years of full-time paid experience as a journey-level electrician.

#### Signal Systems Electrician

1. Completion of a recognized apprenticeship in the electrical trade which provides experience or training in electrical control or electronic control work; or
2. Attainment of journey-level rank in a class at least at the level of electrician and which provides experience in electrical control or electronic work; or
3. Four years of full-time paid experience in a position at least at the level of Electrical Craft Helper in installing, maintaining, or repairing traffic signal, or electrical control, or electronic control work.
4. Thirty semester or 45 quarter units of training in electronics technology, which includes four courses in circuit analysis, digital logic and microprocessor systems may be substituted for each year of helper experience lacking up to a maximum of two years.

The above information was compiled from work done by the Personnel Department in preparing job analysis for examination, classifying jobs, and determining the jobs that would provide qualifying experience for promotional examinations. This information does not replace class specifications and examination bulletins.

## **PREPARING YOURSELF FOR PROMOTION**

1. Broaden your work experience by taking advantage of job rotation and transfer opportunities. Take advantage of on-the-job training opportunities relating to your work.
2. Take advantage of formal education opportunities relating to your work.
3. Learn and stay abreast of laws, procedures, policies and practices relating to your career ladder.
4. Carefully review examination bulletins and class specifications for promotional classes to determine the kinds of skills, knowledges and abilities you need to develop for promotion.
5. Request for Notification cards may be completed in Room 100 of the Personnel Building (847-9240) to notify you by mail when a specific examination is open for filing. Familiarize yourself with the areas in your work location where weekly job bulletins are posted.
6. Employees may obtain career counseling from the Personnel Department's Employee Development Section, (213) 847-9800, in Room 380, Personnel Building.